

Technical data

Column qty	3
Max. Weight Capacity	150KG
Height Range	630-1280mm
Width Range	1100-1900mm
	1260-1860mm

Accessory list

Attention: The drawings below are only for reference which might be slightly different from the actual object, please in kind prevail. Any tools missing or installation problems, please contact the customer service firstly.

No.	Image	Spec	Qty
A		M6	6
B		M6	8
C		M6	12
D		M6	16
E		St4.2	24
F		Wrench 4x4mm	1

Component list

No.	Part	Qty	No.	Part	Qty
①	Feet	3	②	Lifting Column	3
③	Cable Management	2	④	Supporting Beam	1
⑤	Auxiliary beam	1	⑥	Supporting plate	3
⑦	Hand Switch	1	⑧	Control Box	1
⑨	Power cable	1	⑩	Cable	1

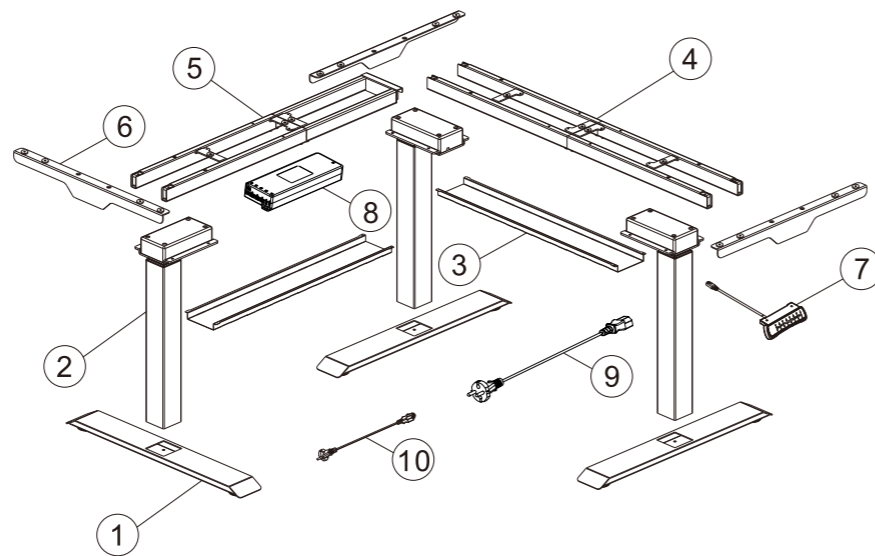

STEP 1

Install supporting beam(4)

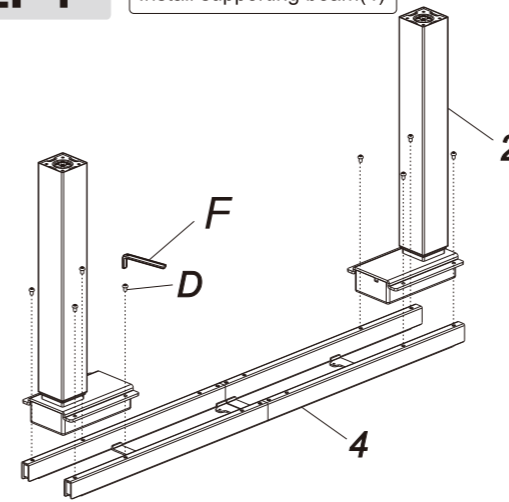

Install lifting column (2) and supporting beam (4) together, use wrench (F) to tighten the screws (D).

Install auxiliary beam(5)

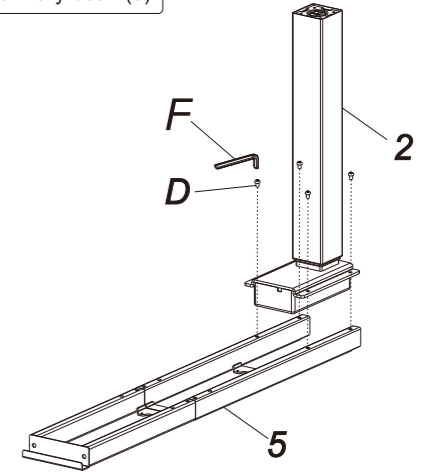

Install lifting column (2) and auxiliary beam (5) together, use wrench (F) to tighten the screws (D).

STEP 2

Install feet (1)

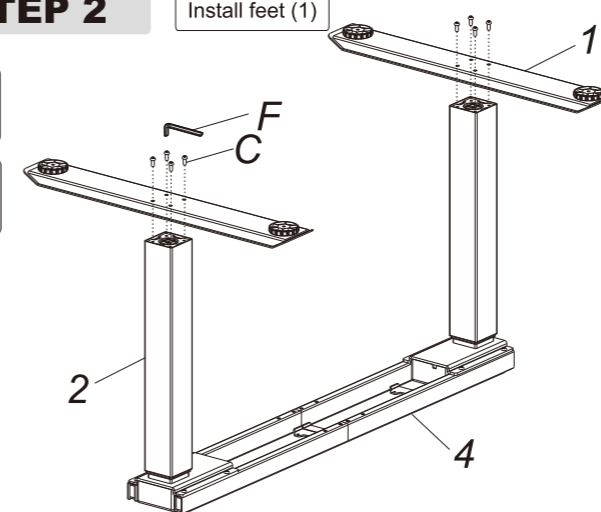

Install feet (1) and lifting column (2) together, use wrench (F) to tighten the screws (C).

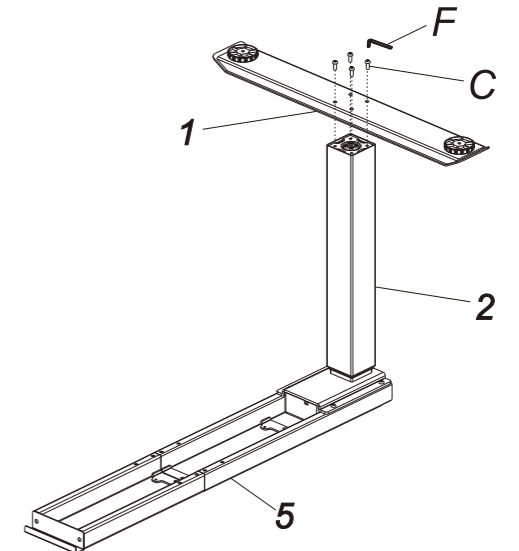

STEP 3

Install Auxiliary beam (5) and Supporting plate (6)

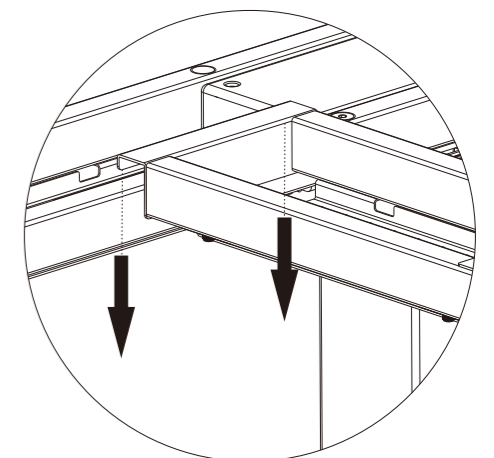
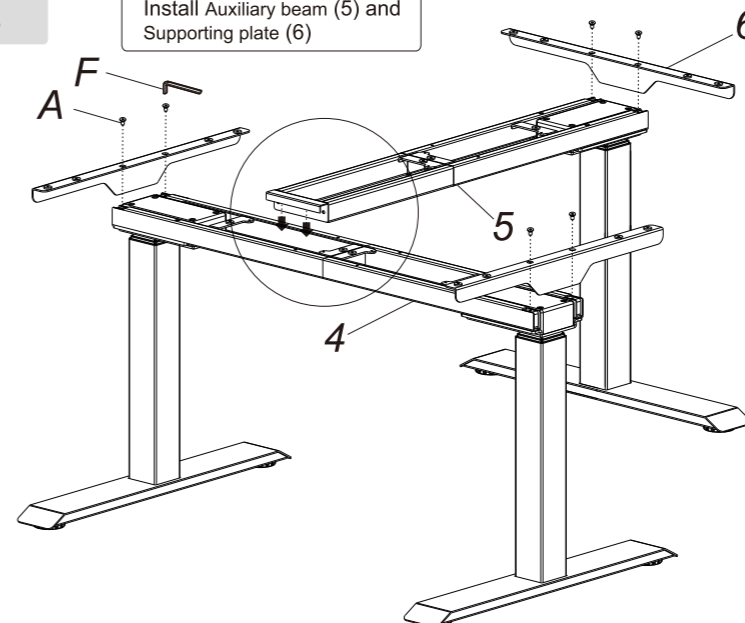

Buckle in the auxiliary beam (5) to the supporting beam (4), and the specific position can be selected according to the tabletop.

STEP 4

Connect All the Cables onto the Control Box(8)

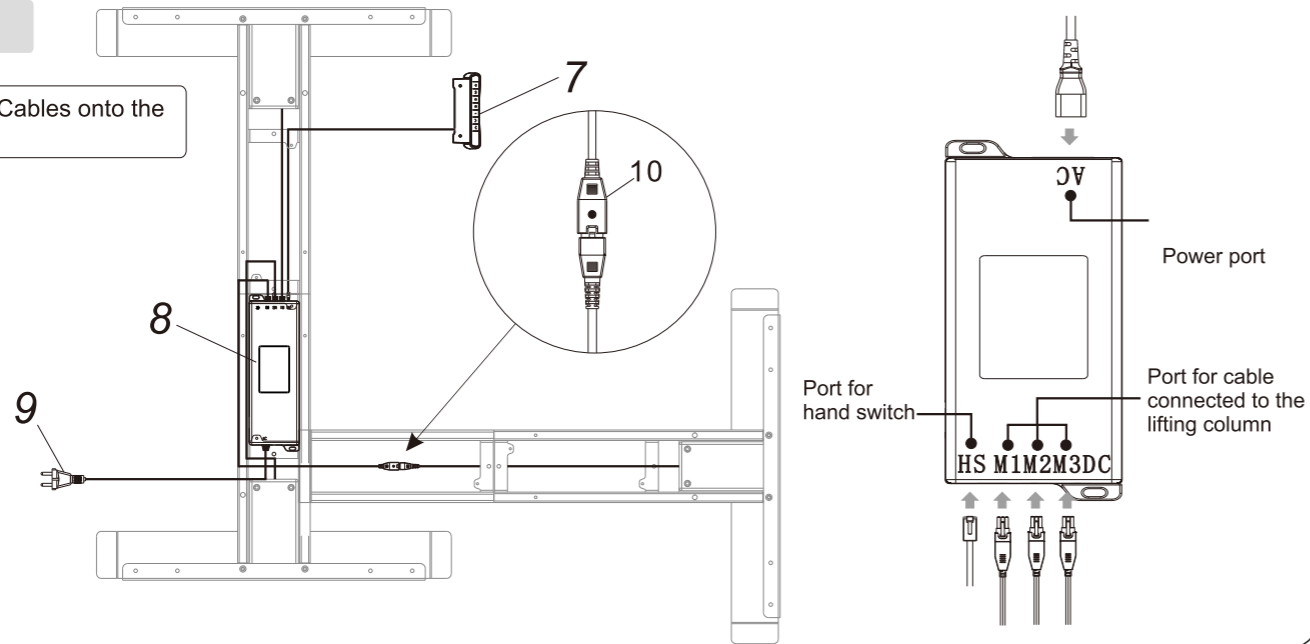

STEP 6-B

Install the Cable Management Tray (3)

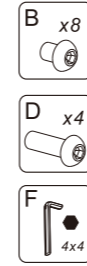

Way 2

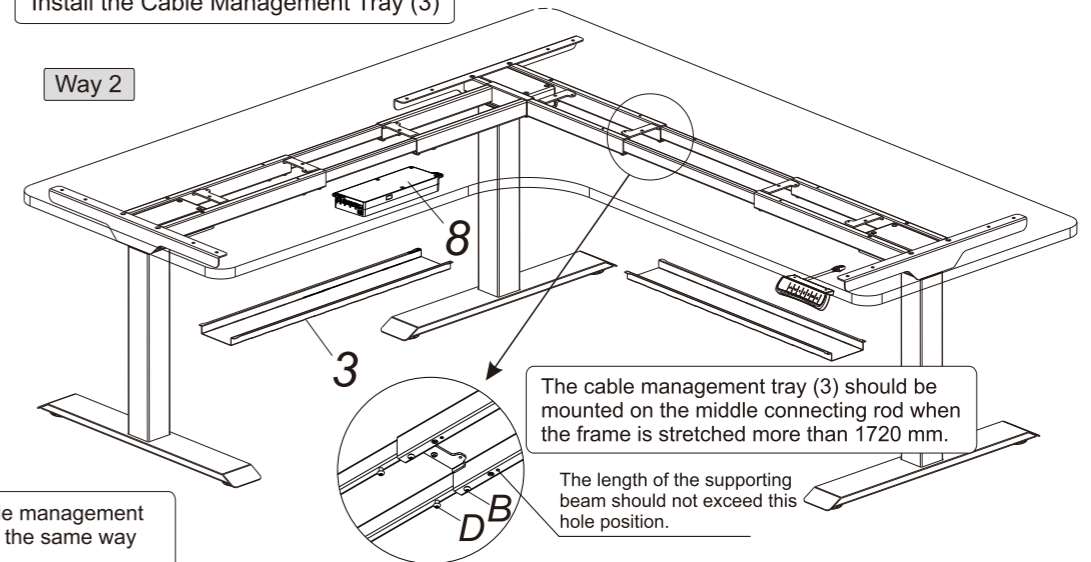

The Installation of cable management tray (3) are installed in the same way as Way 1 in Step 6-A.

STEP 5

Install the Tabletop, Hand Switch(7) and Control Box (8)

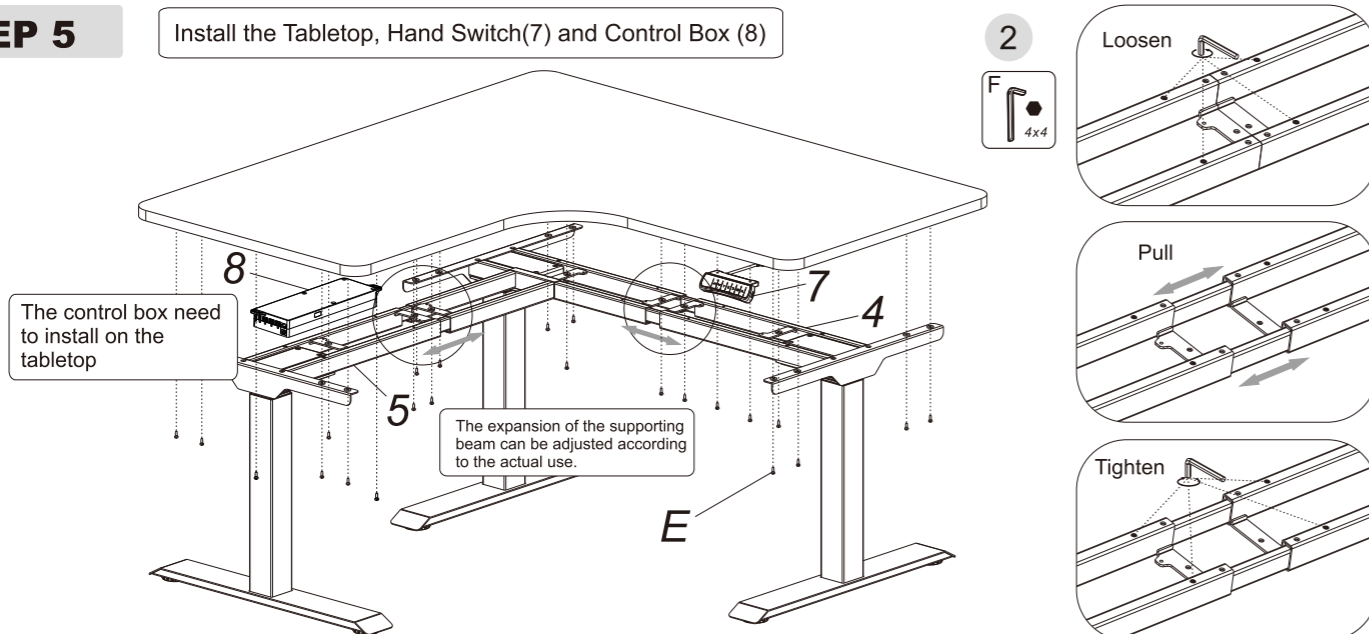

Common fault treatment

The following tips will help you detected and eliminate the common fault and error. If the fault you met is not listed below, please contact with your supplier. Only the manufacturer and professionals are capable for investigating and correcting those fault and error.

Fault phenomenon	Method
No response while long pressing down arrow after connected with a power supply	1. Check if all the cables be connected well 2. Contact your supplier or dealer
No response while pressing up arrow/ down arrow after connected with a power supply	1. Check if all the cables be connected well 2. Contact your supplier or dealer
Rising in a low speed	1. Check if overloaded, max loading: 150kg; 2. Contact your supplier or dealer
The motor not move as instructed	1. Contact your supplier or dealer
Go down but not go up	1. Reposition 2. Contact your supplier or dealer
Downward sliding	1. Check if overloaded, max loading: 150kg; 2. Contact your supplier or dealer
Frequently Reposition	1. Check if overloaded, max loading: 150kg; 2. Contact your supplier or dealer
Overwork (Duty cycle: Max 2min on/18min OFF)	1. Restart after suspend for 18mins while connecting with power; 2. Contact your supplier or dealer;
Not enough up&down height	1. Press "M" and "3" together for 3 seconds or more, after hearing continuous beeping for twice, it will restore factory settings 2. Contact your supplier or dealer



Attention

- Power supply: AC100V-240V,50/60Hz
- Service Environment: 0-40°C
- Unplug the power plug before cleaning, wipe the dust on surface with slight wet dishcloth when cleaning, be careful not to let the drops into the internal parts, not loose the connector.
- The electric box contains electronic components, metals, plastics, wires etc., so dispose of it in accordance with each country's environmental legislation, not the general household waste.
- Check carefully to ensure correct and complete assembly before using.
- Be familiar with all functions and program settings of the product before first use.
- Children are forbidden to play on the product because of unforeseen action when playing, so any dangerous consequences caused by this improper action will not be on.
- Slight noise caused by the V-ribbed belt or brake system due to structure will not have any effect on the use of the equipment.
- Corrosive or abrasive materials are forbidden to clean the equipment. Must ensure that the cleaner used will not pollute the environment.
- This appliance can be used by children aged from 8 years and above and persons with reduced physical, sensory or mental capabilities or lack of experience and knowledge if they have been given supervision or instruction concerning use of the appliance in a safe way and understand the hazards involved. Children shall not play with the appliance.
- Cleaning and user maintenance shall not be made by children without supervision.
- If the supply cord is damaged, it must be replaced by the manufacturer, its service agent or a similarly qualified person in order to avoid a hazard.
- Please make sure there is no hazard sources in your operating environment. e.g., do not litter the tools around. Always be careful to treat the packaging materials in order to avoid any possible danger, e.g. plastic bag may lead to choking hazard to children.
- Keep the original package of the equipment if necessary in case of the future use in transportation.

STEP 6-A

Install the Cable Management Tray (3)



Way 1

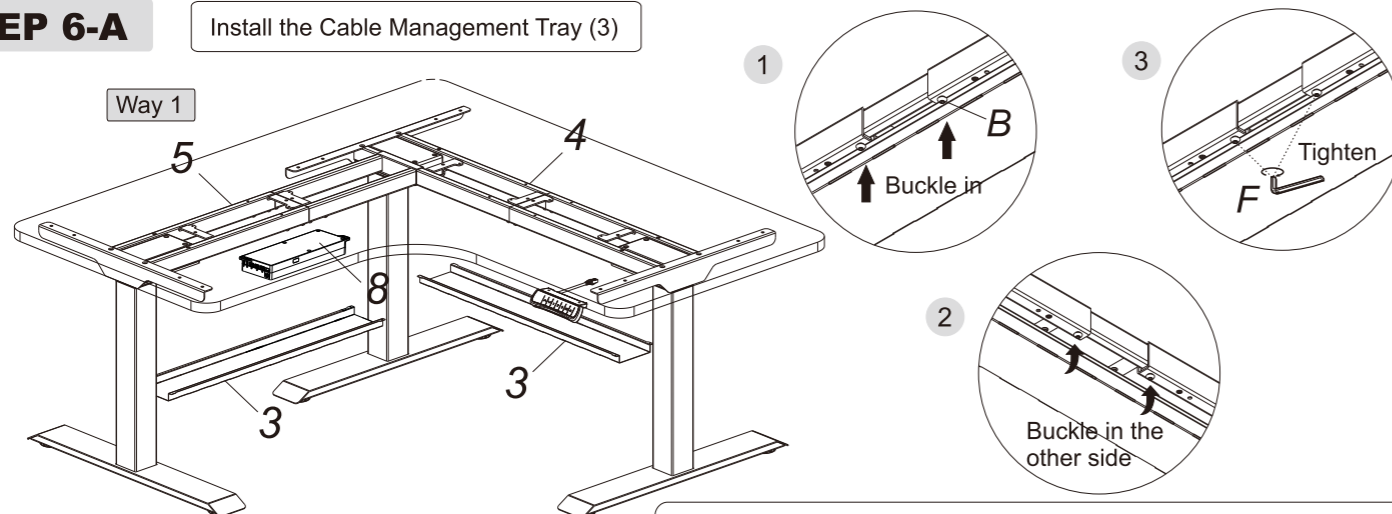

Firstly, screw the screw (B) into the supporting beam (4) with Allen Key (F), and not tighten completely. Buckle one side of the cable management tray (3) into the screw (B), then press the other side into the screw (B). Finally, the screw (B) is locked with Allen Key (F). The cable management tray (3) on the auxiliary beam (5) are installed in the same way.

Waste disposal



This marking indicates that this product should not be disposed with other household wastes. To prevent possible harm to the environment or human health from uncontrolled waste disposal, recycle it responsibly to promote the sustainable reuse of material resources. To return your used device, please use the return and collection systems or contact the retailer where the product was purchased. They can take this product for environmental safe recycling.